

A Structural Equation Model on the Grammatical Competence of College Students

Jerlyn G. Balones, PhD

University of Mindanao
Philippines

Gloria P. Gempes, EdD, DM, PhD

University of Mindanao
Philippines

Abstract

The study explored the students' language attitude, language learning strategies, and language exposure in relation to their grammatical competence. Likewise, it also probed the correlation and the combined and singular influence of the variables. Lastly, this study identified the best fit model for grammatical competence. By means of quantitative-causal method, there were 400 respondents identified through proportional percentage sampling. Product-Moment correlation and multiple-linear regression were used to analyze the correlation and regression analysis. Also, the use of SEM strengthened the integrity and rigor of the research because the analysis goes through the steps of model specification, model estimation, and model evaluation. Results revealed that the level of Students' Study Attitude and language learning strategy are High; the level of Students' Language Exposure is Moderate; the level of Students' Grammatical Competence is High; there is a significant relationship among Attitude, Language Learning Strategy, and Exposure to Grammatical Competence; there is a combined influence among Attitude, Language Learning Strategy, and Exposure to Grammatical Competence. But there is no singular influence among the variables. The best fit model indicates that the grammatical competence is strongly influenced with Language Learning Strategy and Language Exposure.

Keywords: Language and Linguistics, Structural Model, Grammatical Competence, Language Attitude, Learning Strategies, Language Exposure

1. Introduction

Grammatical skill is a problem of employment in developing countries (Foundation for Young Australians, 2012; Kavanagh & Brennan, 2008). The existence of this problem was further confirmed by Hernandez (2015) as he mentioned that McKinsey and Company showed a study that only 13 percent of graduates from emerging countries are suitable for employment in global companies due to lack of skills in English of which Philippines is one. One concrete study on the English language proficiency of graduating business and education students in Metro Manila are at the basic level only. This level of proficiency indicates that the person hardly understands native English speakers. (Macasinag, 2001; Cervantes, 2002).

These problems in learning English language are considered perennial in the field of language teaching. Dornyei (2005) raised these concerns and pointed out that there are variables to consider in language performance. He believes the "the measurement of attitudes towards language in one way or another is likely to remain an indispensable background variable component on L2 studies focusing on language performance". Grammatical competence has long been studied by numerous researchers. The studies of Collins and Bissell (2010) have emphasized that proper grammar is crucial for effective communication. Students demonstrated a limited grasp of the language, struggling with such issues as the distinction between "it's" and "its." Women performed better than men at the beginning of the semester, but the gap later narrowed. There was a correlation between self-efficacy (confidence in one's ability to perform a particular task) and grammar ability at the end of the semester.

Moreover, studies from Barraquio (2015) and Labuan (2015) investigated the grammatical errors committed by students and its relationship to their English language exposure resulted to a conclusion that students with high exposure to English language have significantly less frequency in their writing errors specifically in fragments, parallelism, punctuation, and verb tense (Masangya & Lozada, 2009). The results of these studies suggest that students encounter problems with basic grammatical rules in English such as verb tenses, subject-verb agreement, prepositions, morphology, verbs, articles, and pronouns. These results also shed light on the process through which ESL learners internalize the grammatical rules of English as a target.

These studies also show that learning English as a second language among students has been a perennial problem. After reading several research related to problems in English language learning, still none of these was utilized to confirm what really is the definite reason behind the difficulty of the students to achieve a desirable competence in the use of the English language. This then gave the researchers the interest to study on the possible interplay of students' attitudes, language learning strategies, exposure, and grammatical competence as she considers this necessary in order to address the English language acquisition of university students.

Because of the literatures that the researchers had come across which are related to the relationship of the independent variables, students' attitudes, language learning strategies, and exposure to the dependent variable, grammatical competence, this paper was conceived. Though there were relationship studies on these variables, the researcher had not come across a study involving all the variables in a single study. This makes this study different from those studies on bivariate relationships. This study involves four variables in one setting making it a contribution to the pool of knowledge.

1.1. Research Objective

This study explored a structural model on the grammatical competence of students. Particularly, this study investigated the following objectives:

1. To ascertain the level of study attitudes of students;
2. To ascertain the level of language learning strategies of students in English;
3. To ascertain the level of language exposure of students in English;
4. To ascertain the grammatical competence of students in English;
5. To determine the significant relationship between:
 - 5.1. study attitudes and grammatical competence of students
 - 5.2. language learning strategies and grammatical competence of students
 - 5.3. language exposure and grammatical competence of students
6. To determine the combined and singular influence of study attitudes, language learning strategies, and language exposure on the grammatical competence of students
7. To determine the best fit model of grammatical competence of students in English

2. METHOD

2.1. Participants and Procedure

The data came from the sample size of 400 respondents who were selected through stratified sampling using Slovin's formula at 0.05 level of significance. This study utilized the quantitative causal method in research as this employed gathering varied quantitative data on Student's study attitudes, language learning strategies, language exposure, and grammatical competence as variables. On the vein of the best fit model, Structural Equation Model was used. Compared to other statistical methods, structural equation modeling is a more complex method of data analysis where it determines a structure for the covariance between the observed variables, providing the alternative name covariance structure modeling, thus, offers a more meaningful and valid results (Byrne, 2013). This is an advanced multivariate technique to examine multiple dependence relationships between variables simultaneously.

Using SEM in this study strengthened the integrity and rigor of this research because the analysis goes through the steps of model specification, data collection, model estimation, model evaluation, and possibly model modification. So, when the hypothesized model is rejected based on goodness of fit statistics, an alternative model that fits the data must be made (Lacobucci, 2010; Chen, Curran, Bollen, Kirby & Paxton, 2008).

2.2. Instruments

In achieving the objectives of this study, a contextualized, expert-validated survey questionnaire was utilized as a research instrument. The four-dimensional questionnaire was adopted from existing materials made and used by credible scholars and researchers on the topics: Students Study Attitudes, Language Learning Strategies, Language Exposure, and Grammatical Competence as variables.

The section of the instrument was divided into four.

Part One is the student study attitudes developed by Yu (2010) which intended to measure the attitudes of learners toward English language, attitude toward the current English education policies in the Philippines, and attitudes toward the purposes of how Filipino college students learn English. The 39 items were modified to fit to the locale of the study.

Part two is the SILL survey questionnaire for language learning inventory from Oxford (1990). The SILL instrument was categorized into six parts. The questionnaire was revised based on comments and feedback from the Review Committee, with special attention to issues of simplicity, comprehensibility, and contextual appropriateness.

Part three is the Language Exposure Questionnaire by Magno (2009). This English language exposure survey questionnaire was constructed to determine the level of exposure reflected from different situations where English is spoken. The instrument was validated by two English professors and two psychologists who specialize in psycholinguistic research. In the final form, 23 items were arrived at, after considering the revisions and changes that were suggested.

The last part is the grammatical competence instrument is from the instrument of Yan, (2007) in her study "Grammatical Competence of Fourth Year English Majors of Benguet State University. Benguet State University, La Trinidad, Benguet". The questionnaire consisted of 100-item grammar constructed test in multiple choice type where every correct answer is given a score of "1". The test composed of 20 prepositions, 20 subject-verb agreement, 20 verb tenses, 20 models, and 20 active and passive voices.

2.3. Statistical Analysis

The gathered data were then properly classified, analyzed, and interpreted using the following statistical tools.

Mean. This was used to measure the level of Students Study Attitudes, Language Learning Strategies, Language Exposure, and Grammatical Competence of the students.

Standard Deviation. This was applied to measure the spread of scores within a set of data.

Pearson Product Moment Correlation. This was employed to determine the interrelationships between and among Students Study Attitudes, Language Learning Strategies, Language Exposure, and Grammatical Competence of the students.

Multiple Regression. This was utilized to determine the significant predictors of grammatical competence.

Structural Equation Modeling. This study required the use of SEM to explore best fit model. In testing the factors, there is a need to carry out factor analysis on latent variables suggested a cut-off value of 0.50 while Ullman and Bentler (2003) used 0.45 in modeling construction safety culture. The essence of the test according to Savalei and Bentler (2010) is to ensure the elimination of attributes with low correlations with the attributes of other latent factors in the final SEM. The cut-off value is affected by sample size but a range of 0.45 to 0.50 is deemed appropriate. Further, this tool will be used to determine the model that best fits organizational resilience.

3. RESULTS

3.1. Level of Study Attitudes of Students

It can be noted in Table 1 that the standard deviation in all indicators of Study Attitudes of Students as reflected in Table 1 is less than 1.00, which falls under the typical standard deviation for a five-point Likert-scaled study. This indicates that there is consistency of responses among the respondents of the study.

Table 1

Level of Study Attitudes of Students

Indicator	SD	Mean	Descriptive Level
Attitude towards English	0.37	4.16	High
Attitude towards the Current English Policy	0.41	4.06	High
Attitude towards the Purpose of Learning English	0.49	4.22	Very High
Overall	0.34	4.15	High

Specifically, in the indicator, *attitude towards English language*, it got a mean score of 4.16, described as *High*. This means that the respondents possess high level of attitude towards awareness of different varieties of English. They also

believe that English is an international language, and it is the main tool for communication with people from other countries.

Further, the result postulates that the respondents have positive attitude towards the different perspective of English language policies and practices in the Philippines including the use of textbooks and other references in English. Further, the respondents also believe that all Filipino students should learn English and that they will still be willing to take English even if it is compulsory in school. Also, the respondents possess very positive attitude towards the usefulness of learning English. Moreover, the result also implies that the respondents are interested in English as they want to become proficient in its use for English as a medium for them to achieve their future goals. Moreover, the respondents are positive that learning English is important as it serves as their ticket to achieving a successful university study. The respondents in general have positive attitudes toward the English language as they consider it to be significant in the international arena of education and career advancements.

3.2. Level of Language Learning Strategies of Students

Table 2 features the level of language learning strategies of students in English with the following indicators: *Memory Devices*, *Cognitive Strategies*, *Compensation Strategies*, *Metacognitive Strategies*, *Affective Strategies*, and *Social Strategies* with an over-all mean score of 3.75 described as *High*. Results reveal that all the indicators got a descriptive level of *High*. It further presents an over-all SD of 0.05 which is lesser than 1.0. This indicates that there is consistency of responses among the respondents of the study.

This indicates that the respondents utilize memory devices, primarily for vocabulary learning and not necessarily involving Deep Processing; *Cognitive Strategies*, which involve Deep Processing of Information; *Compensation Strategies*, which make up for missing knowledge; *Metacognitive Strategies*, which involve planning and evaluating one's own learning; *Affective Strategies*, which students use to manage their emotions and motivation; and *social strategies*, which involve learning with others.

Table 2

Level of Language Learning Strategies of Students in English

Indicator	SD	Mean	Descriptive Level
Memory Devices	0.56	3.66	High
Cognitive Strategies	0.69	3.71	High
Compensation Strategies	0.70	3.61	High
Metacognitive Strategies	0.65	3.98	High
Affective Strategies	0.67	3.70	High
Social Strategies	0.71	3.82	High
Overall	0.50	3.75	High

3.3. Level of Language Exposure of Students in English

Table 3 presents the level of language exposure of students in English with the following indicators: *Home*, *Friends and Media* and its over-all mean score of 3.29 described as *Moderate*. Results show that the respondents have low level of language exposure at home. This garnered only a mean score of 2.56, described as *Low* which means that the respondents rarely talk with parents in English and that English is hardly the language they use at home.

For the indicator, exposure with *friends*, it got a mean score of 3.46, described as *High*. This implies that the respondents are highly exposed to speaking English with friends in school and that they can speak English with classmates as they are encouraged to do so especially in the classroom and during class activities.

For the indicator, exposure with *media*, result shows that it garnered a mean score of 3.83, described also as *High*. This implies that the respondents are

Table 3 Level of Language Exposure of Students in English

Indicator	SD	Mean	Descriptive Level
Home	0.79	2.56	Low
Friends	0.63	3.47	High
Media	0.58	3.83	High
Overall	0.51	3.29	Moderate

exposed to the English language as they use online resources for chatting, messaging, browsing, and even in watching movies and listening to music. With the use also of media, they were able to be exposed with magazines, newspapers and ebooks which are written in English.

3.4. Level of Grammatical Competence of Students in English

Table 4 illustrates the level of grammatical competence of students in English with indicators: *Subject-Verb agreement, Prepositions, Modals, Tenses, and Voices* and its over-all mean score of 3.46 described as *High*. The indicators which obtained the highest Standard deviation are the Subject-Verb Agreement and the Modals. This implies that the responses of the respondents on these questions are very varied. As to the mean scores of the indicators, the *subject-verb agreement and modals* achieved 3.73 and 3.41, respectively which are described as *High*.

Table 4

Level of Grammatical Competence of Students in English

Indicator	SD	Mean	Descriptive Level
Subject-Verb Agreement	1.04	3.73	High
Prepositions	0.89	3.38	Moderate
Modals	1.03	3.41	High
Voices	0.96	3.33	Moderate
Overall	0.82	3.46	High

This implies that the grammatical competence of the respondents in these items is high which means that they are highly competent when it comes to the rules for subject verb agreement and the appropriate usage of modals. The indicators, *Prepositions* and *Voices* resulted to mean scores, 3.38 and 3.33, respectively. These are described as *Moderate*. In summary, the overall grammatical competence of the students resulted to a mean score of 3.46, described as *High*. With this, it can be gleaned that the respondents are highly competent in grammar.

3.5. Multiple Regression Analysis of the Influence of Study Attitudes, Language Learning Strategies and Language Exposure on Grammatical Competence

Table 8 flaunts the Multiple Regression Analysis of the Influence of Study Attitudes, Language Learning Strategies and Language Exposure on Grammatical Competence. Using Regression as a tool, it can be gleaned from the result that there is no significant influence in the singular capacities of the variables: study attitudes, language learning strategies, and language exposure to the grammatical competence of the respondents. However, the combined influence of the three independent variables over the dependent variable shows 10.6% significant influence. There is a chance that if the three independent variables work together, then it could imply a 10.6% significance towards the dependent variable, grammatical competence. The combined influence is significant because the p- value is less than 0.05 level of significance. This further means that more than 80 % of the influence can be attributed to other factors beyond this study.

Examining closely, a multiple regression was calculated to predict grammatical competence based on their Study Attitudes, Language Learning Strategies and Language Exposure. A significant regression equation was found in the F value of 15.706, $p < 0.000$, with an R^2 of 0.106. Respondents predicted grammatical competence is equal to 4.476. Grammatical Competence increased at -237 for each increase in study attitudes; -.141 increase for language learning strategies; and 0.153 for each increase in language exposure. None of the study attitudes, language learning strategies and language exposure were significant predictors of grammatical competence when taken altogether in a single study.

Table 8

Multiple Regression Analysis of the Influence of Study Attitudes, Language Learning Strategies and Language Exposure on Grammatical Competence

Grammatical Competence				
(Indicators)	□	□	T	Sig.
ant)	4.476		8.689	.000
Attitudes	-.237	-.099	-1.692	.091
age Learning Strategies	-.141	-.086	-1.389	.166
age Exposure	.153	.094	1.720	.086
R	.326			
R²	.106			
F	15.706			
p	.000			

* $p < .05$

In summary, it could be noted that In the singular capacities of the independent variables, none from the independent variables study attitudes, language learning strategies, and language exposure can significantly influence the dependent variable, grammatical competence. They need the support of each other to significantly influence the dependent variable.

3.6. BEST FIT MODEL

Lastly, Hypothesized Model 5 as seen in Figure 5 is the identified best fit model. It shows the only latent exogenous variable which indicates influence on the latent endogenous variables of this study. The model fitting was calculated as being highly acceptable as presented in Table 10. The chi-square divided by the degrees of freedom is 1.028 with the probability level of 0.422. This indicates a very good fit of the model to the data. This is also strongly supported by its RMSEA index which is less than 0.05 with its corresponding p-value > 0.05 . In the same manner, the other indices such as NFI, TLI, CFI, and GFI were found to consistently indicate a very good fit model as all their values fall within each criterion.

Figure 5.1 shows the structural model standardized solution of language learning strategies and language exposure on grammatical competence. The model indicates that the latent variables language learning strategies represented by the indicators: Metacognitive devices, Cognitive strategies, Compensation strategies, Affective strategies, and Social strategies; and language exposure with indicators: home and friends have significant contributions to the latent variable grammatical competence. It can also be gleaned from the figure that five out of six factors of language strategies and two out of the three factor of language exposure have strong interconnectedness with each other.

Examining closely, the model presents the causal relationship between (LS) language learning strategies to (GC) grammatical competence and (LEX) language exposure to (GC) grammatical competence as represented by the single-headed arrows. It further shows that the latent variables as represented by the oval shapes are the (LS) language learning strategy, (LEX) language exposure and (GC) grammatical competence. Study attitudes is no longer part of the model. As to the observed variables, (MS) metacognition strategies under (LS) language learning strategies is also eliminated. The model also shows that (MED) under (LEX) language exposure is also eliminated, leaving (HOM) home and (FRND) friends as the only observed variables for (LEX). Moreover, residuals as represented by the symbol e are observed among all the indicators of language learning strategies and language exposure. Residuals are also observed in the variables: language exposure and grammatical competence.

Table 9

Summary on the Goodness of Fit Measures of the five Structural Models

Model	CMIN/D F	P- Value	NFI	TLI	CFI	GFI	RMSE A	Pclose
1	5.207	.000	.791	.790	.823	.858	.103	.000
2	3.240	.000	.874	.888	.909	.906	.075	.000
3	3.209	.000	.874	.890	.909	.906	.074	.000
4	2.365	.000	.945	.954	.967	.957	.058	.152
5	1.028	.422	.978	.999	.999	.983	.008	.998

Legend:

ELL	-	English Language Learning
CEP	-	Current English Education in the Philippines
PLE	-	Purposes in Learning English
SA	-	Study Attitudes
MD	-	Memory Devices
CS	-	Cognitive Strategies
COS	-	Compensation Strategies
MS	-	Metacognitive Strategies
AS	-	Affective Strategies
SS	-	Social Strategies
LS	-	Language Learning Strategies
HOM	-	Home
FRND	-	Friends
MED	-	Media
LE	-	Language Exposure
SVA	-	Subject-Verb Agreement
PREP	-	Preposition
MOD	-	Modals
PV	-	Passive Voices
GC	-	Grammatical Competence

Table 10

Goodness of Fit Measures in Structural Model 5

Index	Criterion	Model Fit Value
CMIN/Df	$0 << 2$	1.028
P-value	> 0.05	.422
NFI	$> .90$.978
TLI	$> .90$.999
CFI	$> .90$.999
GFI	$> .90$.983
RMSEA	$< .05$.008
Pclose	$> .05$.998

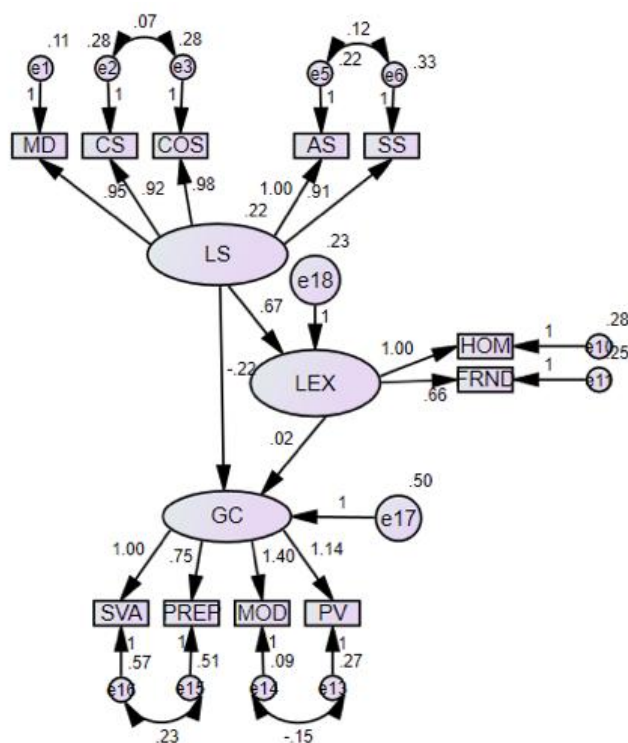

Figure 5.1 Structural Model 5 in Standardized Solution

4. DISCUSSION

4.1. Level of Study Attitudes of Students

The respondents in general have positive attitudes toward the English language as they consider it mandatory to be learned and that even if it is not a compulsory course in school, they are still quite willing to take it. The high-level result of study attitude among the respondents is congruent to the point that attitudes in language learning is a complex phenomenon which is difficult to define. This is evident in the studies of Gardner and MacIntyre (1992); Ellis (1997); Richard and Wu, (2006) of which they have all pointed out consistent relationship between language attitudes to second language achievement. These researchers define constructs on the factors that could affect the language achievement of second language learners. Further they pointed out that affective states of a learner could really influence the degree of effort that a learner makes to learn a second language.

Moreover, the high positive result of students attitude as seen in the statements: *Learning English to catch up with economic and technological developments in the world; An important purpose for English learning is being able to get a decent job; Learning English in order to obtain better education and job opportunities abroad*, can be explained by the Motivational self-system model of Dornyei (2005) for second language learning which states that the second language motivational self-system forms links with conceptualizations of second language learning. Noels (2003) and Ushioda (2001) have also presented their discussion on this theory of which they said that learners include the attributions a person believes they should have in order to meet expectations in their future careers or avoid negative outcomes. The second language learning experience of students includes the situational and environmental aspects of the language learning process as well as one's subjective learning experience. With this, if they have a positive outlook on how and why they learn the language, then a successful language learning is very possible.

4.2. Level of Language Learning Strategies of Students in English

The level of Students' Language Learning Strategy is High. The high level of language strategies are manifested in the statements which indicate the highest mean scores described as *very high*. Achieving high level of strategies can further help the respondents in improving their grammatical skills. This can be supported by O'Malley and Chamot (1990) as they define language learning strategy as "the special thoughts or behaviors that individuals use to help them comprehend, learn or retain new information".

In this study, as the students showed a high level of language learning strategy, it means that they are to develop linguistic and sociolinguistic competence in the target language. In the light of this result, Chamot (2005); Goh (2002b); and Oxford et al (2004) support that when students are only given the chance to explore and discover learning by themselves, then they are expected to a wider horizon in learning a language. However, they have also mentioned of the special thoughts or strategies that individuals use to help them comprehend, learn or retain new information. Thus, taking the findings of this study, it can be surmised that when it comes to grammatical competence, the high level of language learning strategies of the respondents can be their weapon in achieving a significant competence.

This result of Lasagne (2016) holds true with the result of the high level of language learning strategies of the respondents of this study. Examining closely, the respondents of this study obtained a high level in all of the indicators; memory devices, cognitive strategies, compensation strategies, metacognitive strategies, affective strategies and social strategies. However, in the specific statements like *reviewing second language lessons often; reading second language without looking up every word; and writing down feelings in a language learning diary*, respondents only got a moderate level.

Theoretically, the result could further be supported by the Strategy Inventory for Language Learning of Rebecca Oxford (1989) of which it explains that students apply the most useful study skills for their purpose, such as understanding new words and phrases, organize and produce vocabulary and accurate communication. In this study, the respondents showed that they use Metacognitive strategies specifically in centering their learning, arranging, and planning for their learning and even in evaluating their learning.

Finally, the result of this study can be anchored on the Bachman and Palmer's language competence model (1996) which states that organizational knowledge is composed of abilities engaged in a control over formal language structures and this can be in a form of language learning strategies employed by a learner. Possessing language learning strategies enables a learner to comprehend textual knowledge of texts. It covers the knowledge of conventions for combining sentences or utterances into texts, and knowledge of rhetorical organization or conversational organization which will aid their competence in the use English language.

4.3. Level of Language Exposure of Students in English

The level of Students' Language Exposure is Moderate. When the level of language exposure was computed per indicator, the results showed that language exposure at home was *low*; language exposure with friends was *moderate*; and language exposure in terms of media was *High*.

With this result, the points of Bautista (2000); Lee (2003); Jia and Aaronson, (2003) that Philippines had significantly higher English language exposure compared to countries like Taiwan and China never hold true on this study. They further stated that Philippines has a strong socialization process in the use of the English language as Filipinos are exposed more with the English language through engaging in conversations in the second language with family members, friends, classmates and colleagues; whenever they read books, magazines, and newspapers written in that language; whenever they come across information being disseminated in different multimedia sources; or even when they are mere passive listeners in any activity or place in which the second language is being spoken to further enrich their English proficiency.

Specifically, the result of this study is in contrast with Bautista (2000) in his research findings that 51.43% of the families in private schools of the Philippines speak English at home. This made the Taiwanese students develop better English as they spent time in the Philippines. However, this study of Bautista (2000) was conducted in De La Salle University, this could have been the reason that his respondents were able to get high exposure to English speaking students and teachers as speaking English is a normal environment in La Salle. Comparing it to the environment and the language used in the University of Mindanao, in here, students seldom speak in English. They only speak when they are obliged by their teachers to do so and it only happens inside the classroom during class hours. This is evident in the statements: *Friends speaking in English, talking with friends in English when in school and classmates speaking English*. These statements resulted only to a moderate level of exposure among the respondents of this study.

Therefore, it is more about the amount of the right language exposure rather than gaining random exposure from many sources. For instance, practicing English with dormitory peers may not improve one's collocation, rather than practicing the target language with people online. Also, there are some exposures which bring the most advantage for improving knowledge of collocation. Those are exposures from home, especially with parents, exposures from school: the interaction with English teachers and the activities in English class, and exposures from media, especially from chatting online and from sending and receiving text messages.

4.4. Level of Grammatical Competence of Students in English

The level of Students' Grammatical Competence is *High*. Ohno (2011) further pointed out that grammatical competence is the ability to recognize and produce the distinctive grammatical structures of a language and to use them effectively in communication and the ability to use the forms of the language such as sounds, words, and sentence structure.

The findings of this study are in consonance with Canale and Swain as cited in Ohno (2011) who pointed out that grammatical competence is an important concern for any communicative approach whose goals include providing learners with knowledge of how to determine and express accurately the literal meaning of utterances. They believe that knowledge of these rules is crucial in interpreting utterances for social meaning, particularly when there is a low level of transparency between the literal meaning of an utterance and the speaker's intention. Thus, the high level of grammatical competence of the students as manifested in this study is a factor in their university study. Bito (2006) as cited by Grigorenko (2010) asserted that knowledge of use is often referred to as communicative competence and the demonstration of this knowledge as through grammatical performance.

4.5. Correlation between Study Attitudes and Grammatical Competence

There is a significant relationship between study attitudes and grammatical competence as reflected by the p-value of 0.19 and correlation coefficient, $r=-0.118$. These findings are aligned with the statement of Oroujlou and Vahedi (2011) that neglect of attitude can trouble students in language learning. Also, good attitude and language learning are largely instrumental. Moreover, they emphasized on the idea that of the numerous studies conducted about brilliant and talented students but with low attitude and motivation, they have achieved little progress in their language learning. Specifically, studies have shown that in the students' language learning, there are many factors that play outstanding roles. Among these factors are learning strategies and language exposure which are also explored in this study. Attitudes of language learners may affect their language learning proficiency and the successful implementation of language education policies (Yu, 2010; Snow, 2007; Young, 2006). Learners' positive attitudes may lead to increased motivation, which, in turn, may lead to successful attainment of proficiency due to increased input and interaction. (Young, 2010).

4.6. Correlations between Language Learning Strategies and Grammatical Competence

There is a significant positive strong relationship between language learning strategies and grammatical competence. The finding is aligned with the findings of Lasagne (2016) in his study where he concluded that there is a significant relationship that exists between the students' English language proficiency and their academic performance in Science, Mathematics and English. The higher the English language proficiency levels of the students are the higher their academic performance levels in Science, Mathematics and English. Further, Chamot (2005) also cited those studies have confirmed that efficient language learners are skilled at matching strategies to the task they are working on, whereas less successful language learners fall short of the metacognitive knowledge about task requirements needed to select appropriate strategies.

In this study, by nature, the respondents are scarcely utilizing English as their daily used language. The respondents only get to use English when they are in the classroom. More so, the use of English language in the classroom is not even that strictly implemented because there are teachers who never use English as their medium of instruction. With this, gaining significant language learning strategies is weak among the respondents because of poor utilization of the English language.

4.7. Correlations between Language Exposure and Grammatical Competence

This result supports that learning an English language is strengthened if exposure to the language is high. This is in consonance with the findings from the study of Elfiondri (2019) among the Indonesian students who were found to gain high level of exposure in Indonesian language as a formal learning media for years from preschool to higher education has been cognitively planted to be a concept in their mind thus it dominates the students' minds in writing in English. Anent to language exposure, this study showed a high level of exposure in term of media. With this, media can be considered as an informal language learning setting (Bahrani, Sim and Nekoueizadeh, 2014). Students can acquire knowledge through their exposure to movies, books and so on. Media in this study had the most sources of exposure with 11 items. Most of the students, from every level of collocation knowledge, chose English songs and English movies to be the sources they often or always had contact with. This might be due to modern culture that has spread through the internet and television. It was also a matter of personal preferences for hobbies viz. to select a book or browse internet webpages.

The high level of exposure to media conforms with the result of Magno et al (2009) where from the 11 media sources of exposure chatting online, sending text messages, and receiving text messages were the main sources for collocation

acquisition. By practicing English through the internet or on the phone, the students were using the target language in real life situations which were rich with authentic conversations daily. As Magno et al (2009) believes that exposures to the target language may reinforce one's motivation to learn the language itself. This brought benefits for the students' language development, especially in vocabulary acquisition since not only can they use and receive exposure, but they may also get feedback from their conversations.

4.8. Multiple Regression Analysis of the Influence of Study Attitudes, Language Learning Strategies and Language Exposure on Grammatical Competence

In the singular capacities of the independent variables, it showed no significant influence towards the dependent variable. They need each other to significantly influence the dependent variable. The result can be supported by the findings of Oroujlou and Vahedi (2011) that even the brilliant and talented students, have resulted to a little progress in their language competence because of many factors which include: teaching strategies, language learning exposure, cognitive capacities, and behavioural concerns.

In this multiple regression result, it can be surmised that the individual results of the studies of Lasagne (2016); Chamot (2005); Bautista (2000); cannot support the r^2 result of this study. Hence, a structural model would best describe the interrelationship that plays within the variables of this study. Given the interdisciplinary consensus about the significance of the three main determinants in the grammatical competence, the question arises how exactly these factors work and interact with each other in language learning. Theoretically, different mechanisms can be imagined. One may assume a pure additive influence of the three factors meaning that the three factors contribute to grammatical competence independently of each other.

Another possible mechanism is that a high value on one factor is a sufficient condition to reach a high grammatical competence as shown in Table 8. The highest level of grammatical competencies reached if exposure or any of the other variables is high. If this picture is true, this would mean a good message for grammatical programs: It is never enough to enhance just one factor and the learner will reach a high level in grammar. This means that if one of the factors is low, there is a dire need to address this, make the necessary interventions in order to reach the highest grammatical level depending on the other factors. This will also indicate that competence in grammar is impossible if one of the three factors is zero. Such an interpretation is confirmed by Klein and Dimroth (2003) who state that all three factors must be provided for language learning.

4.9. Best Structural Model for Grammatical Competence

The best fit model showed that of the 3 tested indicators, media was eliminated. Though in the appended level of exposure to media resulted to a high level, it did not guarantee its influence on grammatical competence as the model was generated. These results can further be explained by the point of Sternberg et al (2001) as they certify children that are left to the confines of a television or by just hearing conversations made by adults as a form of language learning never progressed into language acquisition. In fact, alternative forms of language exposure such as music, movies and leisure reading materials may contain grammatically incorrect sentences and wrong usage of words. This may disrupt or perhaps confuse the student on the standard lexical format and basic grammar rules.

Parallel to this, the outcomes of this study opined to the work of Maliwonski as cited by Mongcal (2016) on context of situation. The concept presents that language learning also comes to life when used in a context. Language is seldom experienced in isolation but always in relation to a scenario, to people, actions, or events. Moreover, it is pointed out the development of competence in understanding social context and strategic competence pertaining to coping strategies used in unfamiliar contexts strongly need very high language learning strategies to successfully achieve grammatical competence. Thus, students may be exposed to English language through social media and other forms but the appropriateness of the contents of what they hear, read and see is the big question whether these are grammatically correct or not. If not, then students are exposed to the wrong mechanics of grammar making them incompetent to it.

The model further showed residuals as represented by the error. The residuals observed in language exposure and grammatical competence can also be considered as explorable factors to investigate wherein these are considered as a manifestation that there are other indicators which may significantly affect exposure and competence of the students.

The generated best fit model conforms with the idea of Nurhidayati, Yasin and Fata (2016) in their study conclusion saying that the more language exposures students get, the more collocation knowledge they will retain in their memory. The second point is that even though language exposure is crucial, not every source of exposure can bring much benefit in gaining collocation knowledge. Therefore, it is more about the amount of the right language exposure rather than gaining random exposure from many sources. For instance, practicing English with dormitory peers may hardly improve one's collocation, rather than practicing the target language with people online. The last summary is that there

are some exposures which bring the most advantage for improving knowledge of collocation. Those are exposures from home, especially with parents, exposures from school: the interaction with English teachers and the activities in English class, and exposures from media, especially from chatting online and from sending and receiving text messages.

The independent variable study attitude never appeared in the best fit model. The best fit model then rejects the claim that a strong, positive self-perception creates a well-spring of incentive and motivation for further challenges. These types of students envision success and can self-regulate, that is, persevere with determination. They can continue their efforts until the goal is obtained.

Conclusion

The use of structural equation model strengthened the integrity and rigor of this research because the analysis goes through the steps of model specification, model estimation, and model evaluation. Results revealed that the level of Students' Study Attitude is *High*; the level of Students' Language Learning Strategy is *High*; the level of Students' Language Exposure is *Moderate*; the level of Students' Grammatical Competence is *High*; there is a significant relationship among Attitude, Language Learning Strategy and Exposure to Grammatical Competence; there is a combined influence among Attitude, Language Learning Strategy, and Exposure to Grammatical Competence. But there is no singular influence among the variables. Of the five explored structural models, only model 5 had the indices that consistently indicated an outstanding fit to the data; therefore, it is identified as the best fitting structural model. This model indicates that the grammatical competence is strongly influenced with Language Learning Strategy and Language Exposure.

The success of the students' grammatical competence can be attributed to many factors. These factors may have been postulated by other studies to manifest grammar proficiency such as those in the studies of Kinsch (2011), Gamaroff (1998), Yigzaw (2011) and many others. It is probable that other factors which manifest more extensively in the respondents were not among those included in this study. The model fit for grammatical competence is in consonance with what Murcia (2001); Canale and Swain (1980); Savignon (1972); Byram (1997) explained about the interconnectedness of series of utterances, written words, and or phrases to form a text, a meaningful whole. Nevertheless, they pointed out the development of competence in understanding social context and strategic competence pertaining to coping strategies used in unfamiliar contexts strongly need very high language learning strategies in order to successfully achieve grammatical competence. In addition, the concept of Maliwonski as cited by Mongcal (2016) on context of situation could support the best fit model as the concept presents that language learning also comes to life when used in a context. Language is never experienced in isolation but always in relation to a scenario, to people, actions, or events.

References

- Aina, J. K., Ogundele, A. G., and Olanipekun, S. S. (2014), Students' proficiency in English language relationship with academic performance in science and technical education. *American Journal of Educational Research*, 9, 355-358, September 2014. DOI: 10.18178/ijll.2016.2.2.65.
- AI-Ansari, S. (2001). Two types of language exposure as predictors of students' academic success in EFL: a case study of undergraduate students at the university of Bahrain. *Journal of King Saud University Languages & Translation*, 13, 91 – 108.
- Anderson, N. J. (2002). The Role of Metacognition in Second Language Teaching and Learning. *ERIC Digest*. Retrieved from: <https://eric.ed.gov/?id=ED463659>.
- Arani, J. (2004). *Issues of learning EMP at university: An analysis of students' perspectives*. Karan's Linguistics Issues. Retrieved from: <http://www3.telus.net/linguisticsissues/>.
- Al-Tamimi, A., & Shuib, M. (2009). Motivation and attitudes towards learning English: A study of petroleum engineering undergraduates at Hadhramout University of Sciences and Technology. *GEMA Online® Journal of Language Studies*, 9(2).
- Bachman, L.F., & Palmer, A.S. (1996). *Language testing in practice: Designing and developing useful language tests*. Oxford etc.: OUP.
- Bahrani, T., Sim, T. S., & Nekoueizadeh, M. (2014). Second Language Acquisition in Informal Setting. *Theory & Practice in Language Studies*, 4(8).
- Barraquio, D. T. (2015). *Grammar Proficiency of Colegio de San Juan de Letran Calamba College Students*. Retrieved from <http://ejournals.ph/form/cite.php?id=6780>.
- Bautista, M.L.S. (2000). *Defining standard Philippine English*. Manila: DLSU Press.

- Becker, B. (2007). Exposure is not enough: The interaction of exposure and efficiency in the second language acquisition process. *The International Journal of Language Society and Culture*, 23(1), 1-9. Retrieved from doi=10.1.1.582.9473&rep=rep1&type=pdf.
- Bernat, E. (2006). Assessing EAP learners' beliefs about language learning in the Australian context. *Asian EFL Journal*, 8(2), 202-227.
- Bito, H.G. (2006). Grammatical Competence of Freshman High School Students of BCNHS Fort Del Pilar Annex. Unpublished Master's Thesis. Benguet State University. Retrieved from: www.BSU.online/lib.edu.
- Boesel, D. (2001). Student Attitudes toward High School and Educational Expectations.
- Brains, C., Willnat, L., Mannheim, J., & Rich, R. (2011). *Empirical Political Analysis 8th edition*. Boston, MA: Longman.76.
- Brown, P., & Levinson, S. C. (1987). *Politeness: Some universals in language usage 4*. England. Cambridge University Press.
- Butler, Y. G. (2004). What level of English proficiency do elementary school teachers need to attain to teach EFL? Case studies from Korea, Taiwan and Japan. *TESOL Quarterly*, 38, 245-277.
- Butler, Y. G. (2007). Foreign language education at elementary schools in Japan: Searching for solutions amidst growing diversification. *Current Issues in Language Planning*, 8(2), 129-147.
- Byrne, B. M. (2013). *Structural equation modeling with LISREL, PRELIS, and SIMPLIS: Basic concepts, applications, and programming*. United Kingdom. Psychology Press.
- Cabaysa, C. C., & Baetiong, L. R. (2010). Language learning strategies of students at different levels of speaking proficiency. *Education Quarterly*, 68(1).
- Canale, M., & Swain, L. (1980). Theoretical bases of communicative approaches to second language teaching and testing. *Applied Linguistics 1:1-47*.
- Canale, M. (1987). The measurement of communicative competence. *Annual Review of Applied Linguistics*, 8, 67-84 doi:10.1017/S0267190500001033.
- Carrier, K. A. (2003). Improving high school English language learners' second language listening through strategy instruction. *Bilingual Research Journal*, 27(3), 383-408.
- Chen, Y. L. (2002). The influences of kindergarten English immersion programs in Taiwan on young children's adaptations to and perceptions of Chinese and English languages and cultures. University of Wisconsin—Madison. *English Teaching & Learning*, 30(4), 87-109.
- Chen, F., Curran, P. J., Bollen, K. A., Kirby, J., & Paxton, P. (2008). An empirical evaluation of the use of fixed cutoff points in RMSEA test statistic in structural equation models. *Sociological Methods & Research*, 36(4), 462-494.
- Chamot, A. U. (2005). The Cognitive Academic Language Learning Approach (CALLA): An update. In P. A. Richard-Amato & M. A. Snow (Eds.), *Academic success for English language learners: Strategies for K–12 mainstream teachers* 87–101. White Plains, NY: Longman.
- Chamot, A. U., & Keatley, C. W. (2003, April). *Learning strategies of adolescent low-literacy Hispanic ESL students. In Annual Meeting of the American Educational Research Association, Chicago, IL.*
- Chamot, A., & El-Dinary, P. B. (1999). Children's learning strategies in language immersion classrooms. *The Modern Language Journal*, 83(3), 319-338.
- Chomsky, A.N. (2006). *Language and Mind, Editia a III-a*, Cambridge University Press, 4. United Kingdom.
- Chilkiewicz, K. (2015). Direct Language Learning Strategies in the theory by Rebecca Oxford in English vocabulary acquisition at the age group of 11-12 year olds. *World Scientific News*, (7), 179-206.
- Chiswick, B. R., & Miller, P. W. (1998). English language fluency among immigrants in the United States. *Research in Labor Economics*, 17(9), 151-200.
- Chomsky, N. (1965). *Aspects of the theory of syntax*. Cambridge Mass. MIT press.
- Chomsky, N. (1981). *Rules and representation*. Basil Blackwell:Oxford.
- Cohen, L. G. (1998). *Assessment of Children and Youth*. Longman, A Division of Addison Wesley Longman, Inc., 1900 East Lake Avenue, Glenview, IL 60025.
- Cohen, A. D. (2003). The learner's side of foreign language learning: Where do styles, strategies, and tasks meet?. *IRAL*, 41(4), 279-292.
- Cojuangco, T. (January, 2012) The state of the nations English (SONE) and what we can do about it. Philstar.com. Retrieved September, 18, 2013 from [http:// www.philstar.com/sunday-life/765648/state-nations-english-son- and-what-we-can-do-about-it](http://www.philstar.com/sunday-life/765648/state-nations-english-son- and-what-we-can-do-about-it).

- De Carvalho, M., Magno, C., Lajom, J., Regodon, J., & Bunagan, K. (2006). *Factors involved in the use of second language learning strategies and oral proficiency among Taiwanese students in Taiwan and in the Philippines*. Paper presented at the Regional English Language Conference, Singapore.
- Deterding, D. (2005). Listening to estuary English in Singapore. *TESOL Quarterly*, 39(3), 425-440.
- Díaz-Rico, L. T., & Weed, K. Z. (2010). *The crosscultural, language, and academic development handbook: A complete K-12 reference guide (4th ed.)*. Boston: Allyn & Bacon.
- Dornyei, Z. (2005). *The psychology of the language learner: Individual differences in second language acquisition*. Mahwah, NJ: Lawrence Erlbaum.
- Elfiondri (2019). Inter-lingual Errors of Indonesian-English in Relation to English Composition: The Case of Bung Hatta University EFL Students, Indonesia. *The Asian EFL Journal*, 24-4-1-2019.
- Foundation for Young Australians. (2012). *Developing skills for life and work: Accelerating social and emotional learning across South Australia*. Retrieved : August 10, 2017 from The Australian Centre for Innovation: https://www.fya.org.au/app/theme/default/design/assets/publications/2012.04.12_Kahn-et-al-2012.pdf.
- Fraser, B., & Rintell, E. (1980). *An approach to conducting research on the acquisition of pragmatic competence in a second language*. Newbury House, Publishers Inc, Rowley Massachusetts.
- Freeman, D. E., & Yvonee, S. Freeman. (2004). *Essential linguistics what you need to know to teach*. Portsmouth: Heinemann.
- Gao, C. Z. (2001). Second language learning and the teaching of grammar. *Education*, 2, 326- 336.
- Gardner, R. C. (1985). The role of attitudes and motivation in second language learning: Correlational and experimental considerations. *Language Learning*, 35(2), 207-227.
- Gardner, R. C., & MacIntyre, P. D. (1992). A student's contributions to second language learning. Part 1: Cognition variables. *Language Teaching*, 15, 211-220.
- Graham, S., Harris, K. R., & Troia, G. A. (2000). Self-regulated strategy development revisited: Teaching writing strategies to struggling writers. *Topics in Language Disorders*, 20(4), 1-14.
- Gregory, G. H., & Chapman, C. (2013). *Differentiated instructional strategies: One size doesn't fit all*. Corwin Press. United Kingdom.
- Goh, S. C. (2002). Managing effective knowledge transfer: an integrative framework and some practice implications. *Journal of Knowledge Management*, 6(1), 23-30.
- Haibach, A. (2000). Finding out about students' learning strategies by looking at their diaries: a case study. *System*, 28(1), 85-96.
- Harper, C., & de Jong, E. (2004). Misconceptions about teaching English-Language Learners. *Journal of Adolescent & Adult Literacy*, 48, 152-162.
- Hernandez, B. (2015, July 11). *English proficiency as a competent edge*. Retrieved from <http://opinion.inquirer.net/english-proficiency-as-a-competitive-edge#ixzz4nMYciFGH>.
- Herrera, S. G., & Murry, K. G. (2005). *Mastering ESL and bilingual methods, Differentiated instruction for culturally and linguistically diverse (CLD) students*. Boston: Pearson Education Inc.
- Hismanoglu, M. (2002). Language learning strategies in foreign language learning and teaching. *The Internet TESL Journal*, 6(8), 1-6.
- Horwitz, E. K., Horwitz, M. B., & Cope, J. (1986). Foreign language classroom anxiety. *The Modern Language Journal*, 70(2), 125-132.
- Hsiao, T. Y., & Oxford, R. L. (2002). Comparing theories of language learning strategies: A confirmatory factor analysis. *The Modern Language Journal*, 86(3), 368-383.
- Hymes, D. (1972). On Communicative Competence. In Bride J. B., Holmes J., (editors), *Sociolinguistics*, Harmondworth, Penguin, 1972, 284.
- Jia, G., & Aaronson, D. (2003). A longitudinal study of Chinese children and adolescents learning English in the United States. *Applied Psycholinguistics*, 24(01), 131-161.
- Jia, G. (2003). The acquisition of the English plural morpheme by native Mandarin Chinese-speaking children. *Journal of Speech, Language, and Hearing Research*, 46(6), 1297-1311.
- Ji, L. J., Zhang, Z., & Nisbett, R. E. (2004). Is it culture or is it language? Examination of language effects in cross-cultural research on categorization. *Journal of Personality and Social Psychology*, 87(1), 57.
- Karahan, F. (2007). *Language attitudes of Turkish students towards the English language and its use in Turkish context*. Retrieved from: <http://dergipark.gov.tr/download/article>. DOI: 45261.
- Kavanagh, M. H., & Brennan, L. (2008). What skills and attributes does an accounting graduate need? Evidence from student perceptions and employer expectations. *Accounting & Finance*, 48(2), 279-300.

- Kim, D. D., & Margolis, D. (2000). Korean student exposure to English listening and speaking: Instruction, multimedia, travel experience and motivation. *The Korea TESOL Journal*, 3, 29-52.
- Kinsch, A. (2011). *First language grammar proficiency and language aptitude: Predictors of choice and success in a second language*. Retrieved from http://purl.flvc.org/fdu/fdu/FDU_migr_uhm-0022.
- Kovacic, A., Kirinic, V., & Divjak, B. (2009). Linguistic competence in tertiary-level instruction in English and its relevance for student mobility. *Journal of Information and Organizational Sciences*, 33(1), 25-37. DOI: 811.111:378 .
- Krashen, S. (1989). We acquire vocabulary and spelling by reading: Additional evidence for the input hypothesis. *The Modern Language Journal*, 73(4), 440-464.
- Krashen, S. D. (1982). *Child-Adult Differences in Second Language Acquisition. Series on Issues in Second Language Research*. Rowley Massachusetts. Newbury House Publishers, Inc.
- Kroger, O. (2005). *Report on a survey of coastal Makua dialects*. SIL (Société Internat. de Linguistique).
- Labuan, R. A. (2015). *An analysis of weblogs' grammatical errors of Filipino learners of English as second language*. Retrieved from: http://www.dlsu.edu.ph/conferences/dlsu_research_congress/2015/proceedings/LLI/006LLI_Mabuan_RA.pdf.
- Lan, R. L. (2005). *Language learning strategies profiles of EFL elementary school students in Taiwan* (Doctoral dissertation). De La Salle University.
- Lan, L. R. (2003). *Learning strategy profiles and strategy Instruction for elementary school learners in Taiwan*. Paper presented at the 2003 TESOL Convention, Baltimore, Maryland.
- Lasagne, L.B. (2016). *Students' language competence*. (unpublished thesis). School of Business and Economics, Manila.
- Latchanna, G., & Dagnev, A. (2009). Attitude of teachers towards the use of active learning methods. *E-journal of All India Association for Educational Research*, 21(1). Retrieved from <https://pdfs.semanticscholar.org/3b12/38ab4320fa08afc02aafae140179566e14a1.pdf>.
- Lee, W. N. (2003). Attitudes toward advertising: A comparative study of consumers in China, Taiwan, South Korea and the United States. *Journal of International Consumer Marketing*, 15(2), 5-23. Retrieved from https://www.tandfonline.com/action/showCitFormats?DOI:10.1300/J046v15n02_02.
- Lennartsson, F. (2008). *Students' motivation and attitudes towards learning a second language. British and Swedish students' points of view* (Dissertation). Retrieved from <http://urn.kb.se/resolve?> .
- Lee, J. S. (2002). The Korean language in America: The role of cultural identity in heritage language learning. *Language culture and curriculum*, 15(2), 117-133.
- Lee, O. (2005). Science education with English language learners: Synthesis and research agenda. *Review of Educational Research*, 75(4), 491-530.
- Levinson, S.C. 1983 *Pragmatics*. Cambridge university press. United Kingdom.
- Li, L., & Yanlong, Y. (2005). Teaching and learning genuine English through news reading and listening. *Sino-US English Teaching*, 2, 24 – 27.
- Liu, D. (2004, November). EFL proficiency, gender and language learning strategy use among a group of Chinese technological institute English majors. *ARECLS-E Journals*, 1, 20-28.
- Macasinag, T. (2001). *Glowing Ember*. Retrieved 2012-10-07 from <http://www.sunstar.com.ph/baguio/opinion/2011/08/04/macasinag-decline-english-proficiency-170862>.
- MacIntyre, P. D., & Gardner, R. C. (1991). Methods and results in the study of anxiety and language learning: A review of the literature. *Language learning*, 41(1), 85-117.
- Magno, C. (2009). How I learned to speak English: Factors involved in ESL acquisition among Filipinos. *Philippine ESL Journal*, 3, 127-141.
- Magno, C. (2010). Korean students' language learning strategies and years of studying English as predictors of proficiency in English.
- Magno, C., Filho, M. K., Lajom, J. A., Regodon, J. R., & Bunagan, K. S. (2009). Assessing the level of English language exposure of Taiwanese college students in Taiwan and the Philippines. *Asian EFL Journal*, 11(1), 62-73.
- Margolis, D. (2000). Korean student exposure to English listening and speaking: Instruction, multimedia, travel experience and motivation. *The Korea TESOL Journal*, 3(1), 29-54.
- Masangya, E. M., & Lozada, L. (2009). An Investigation on the relationship between the language exposures and errors in English essays of high school students. *Philippine ESL Journal*, V- 2, 31-47. Retrieved from <http://www.philippine-esl-journal.com/wp-content/uploads/2014/01/>.
- Matsunda, A. (2000). *Japanese attitudes toward English: A case study of high school students*. Purdue e- Pubs (Dissertation). retrieved from

- <http://www.lib.purdue.edu>.
- Mitchell, R., Myles, F., & Marsden, E. (2013). Second language learning theories. Routledge. 3, 224-259.
- Mitchell, R., & Myles, F. (2001). Second language learning: Key concepts and issues. *English language teaching in its social context*, 11-27.
- Mongcal, P. (2016). Path analysis on the factors influencing grammatical competence. (unpublished thesis) .Ateneo de Davao University.
- Murcia, M. (2001). Language teaching approaches: An overview. *Teaching English as a second or foreign language*, 2, 3-10.
- National Reading Panel (U.S.), & National Institute of Child Health and Human Development (U.S.). (2000). Report of the National Reading Panel: Teaching children to read : an evidence-based assessment of the scientific research literature on reading and its implications for reading instruction : reports of the subgroups. Washington, D.C.: National Institute of Child Health and Human Development, National Institutes of Health.
- Noels, K. A. (2003). Learning Spanish as a second language: Learners' orientations and perceptions of their teachers' communication style. In Z. Dörnyei (Ed.), *Attitudes, orientations, and motivations in language learning* (pp. 97-136). Oxford: Blackwell.
- Nunan, D. (1998). Teaching grammar in context. *ELT journal*, 52(2), 101-109. Retrieved from http://www.lenguasvivas.org/campus/files/0_49/teachinggrammarincontext.pdf.
- Nurhidayati, EndangKomariah, Burhanuddin Yasin, & IkaApriani Fata. (2016). Investigating Students' Language Exposure in Achieving their Knowledge of Collocation. Retrieved from <https://www.academia.edu/28354428/>.
- Ok, L. K. (2003). The relationship of school year, sex and proficiency on the use of learning strategies in learning English of Korean junior high school students, *Asian EFL Journal*, 5(3), 1-35. Retrieved from <http://citeseerx.ist.psu.edu/viewdoc/download?doi=10.1.1.610.5225&rep=rep1&type=pdf>.
- Ohno, A. (2011). *Communicative competence and communicative language teaching*. 2 .Retrieved from: <http://cicero.u-bunkyo.ac.jp/lib/kiyo/fsell2002/25-32.pdf>.
- O'malley, J. M., & Chamot, A. U. (1990). *Learning strategies in second language acquisition*. United Kingdom. Cambridge University Press.
- O'Malley, J. M., Chamot, A. U., Stewner- Manzanares, G., Kupper, L., & Russo, R. P. (1985). Learning strategies used by beginning and intermediate ESL students. *Language Learning*, 35(1), 21-46.
- Oroujlou, N., & Vahedi, M. (2011). Motivation, attitude, and language learning. *Procedia-Social and Behavioral Sciences*, 29, 994-1000.
- Oxford, R., Cho, Y., Leung, S., & Kim, H.J. (2004). Effect of the presence and difficulty of task on strategy use: An exploratory study. *IRAL, International Review of Applied Linguistics in Language Teaching*, 42(1), 1-47.
- Oxford, R. L. (1990). *Language learning strategies: What every teacher should know*. New York: Newbury House Publishers.
- Oxford, R. L. (1989). Use of language learning strategies: A synthesis of studies with implications for strategy training. *System*, 17(2), 235-247.
- Oxford, R.L. (1985). *Old English Syntax: Concord, the parts of speech, and the sentence*. Oxford University Press, USA.
- Oxford, R. (1999). Relationships between second language learning strategies and language proficiency in the context of learner autonomy and self-regulation. *Revista Canaria de Estudios Ingleses*, 38, 108-26.
- Palermo, F., Mikulski, A. M., Fabes, R. A., Hanish, L. D., Martin, C. L., & Stargel, L. E. (2014). English exposure in the home and classroom: Predictions to Spanish-speaking preschoolers' English vocabulary skills. *Applied Psycholinguistics*, 35(6), 1163-1187.
- Palmer, S. E. (1978). Fundamental Aspects of Cognitive Representation. In E. Rosch (Ed.), *Cognition and Categorization*. 259-303. Hillsdale, NJ: Erlbaum.
- Platon, R. (2012). English language proficiency and employment: A case study of Bangladeshi graduates in Australian employment market. *Mevlana International Journal of Education (MIJE)*. Vol. 3(1), 68-81, 1.
- Pressley, M. (2000). More about the development of self-regulation: Complex, long- term, and thoroughly social. *Educational Psychologist*, 30(4), 207-212.
- Riney, T. J., & Inutsuka, K. (2005). Phonetic parameters and perceptual judgments of accent in English by American and Japanese listeners. *Tesol Quarterly*, 39(3), 441-466.
- Robelle, M.A., Racca, A.B., and Lasaten, R.C.S. (2016). English Language Proficiency and Academic Performance of Philippine Science High School Students. *International Journal of Languages, Literature and Linguistics*, 2,2, June 2016. DOI: 10.18178/ijll.2016.2.2.65.

- Ruba, H., Habiba, U., Amir, A., Aslam, A., & Kiran, S. (2014). Strategy Inventory for Language Learning. *European Journal of Psychological Research*, 1(1)10-27. Retrieved from <http://www.idpublications.org/wp-content/uploads/2014/11/Strategy.pdf>.
- Savignon, S.J. (2011). Communicative language teaching: Linguistic theory and classroom practice. 2 December 2011. http://yalepress.yale.edu/excerpts/0300091567_1.pdf.
- Scales, J., Wennerstrom, A., Richard, D., & Wu, S. H. (2006). Language learners' perceptions of accent. *Tesol Quarterly*, 40(4), 715-738.
- Schumann, J. (1975). *Affective Factors and the Problem of Age in Second Language Acquisition*. Retrieved from <https://onlinelibrary.wiley.com/doi/abs/10.1111/j.1467-1770.1975.tb00242.x>.
- Schunk, D. H., & Zimmerman, B. J. (2012). Motivation an essential dimension of self-regulated learning. In *Motivation and self-regulated learning* (pp. 13-42). Routledge.
- Shamis, W. A. (2003). Language Learning Strategy Use in Palestine. *TESL-EJ* 7, 2, 3- 21. Retrieved from: <http://www.tesl-ej.org/wordpress/issues/volume7/ej26/ej26a3/>.
- Shen, W.W.(2003). Current trends of vocabulary teaching and learning strategies for EFL settings. *Fen Chia Journal of Humanities and Social Science*, 7, 187-224.
- Snow, C. (2007). Cross-cutting themes and future research directions. *Developing Literacy in Language Learners: Report of the National Literacy Panel on Language, Minority Children and Youths*, 275-300.
- Spolsky, B. (2011). *Communicative competence, language proficiency, and beyond*. 16 November 2011. <http://applied.oxfordjournals.org/content/10/2/138.short>.
- Steinberg, D., Nagata, H., & Aline, D. (2001). (Eds.). *How children learn language. Psycho-linguistics: Language, mind and the world*. Harlow, England: Pearson Education.
- Stern, M. (2012). Review of research exploring school attitude and related constructs. In *Evaluating and promoting positive school attitude in adolescents*. Springer, Boston, MA. DOI:10.1007/978-1-4614-3427-6_2,19-28.
- Suarez, D., Anabieza, K., and Musni-Tagaytay, M. (2014). Predictors of grammar proficiency of selected students from selected higher education institutions in Davao city. *UIC Research Journal*. 20,1, 27-37.
- Swain, M. (2005). *The Output Hypothesis: Theory and Research*. Handbook of research in second language teaching and learning, 1, 471-483.
- Tuan, V.V. (2017). English Language Teaching. Communicative Competence of the Fourth Year Students: Basis for Proposed English Language Program. 10,7; 2017. DOI: 10.5539.104.
- Ullman, J. B., & Bentler, P. M. (2003). *Structural equation modeling*. John Wiley & Sons, Inc.
- Unsworth, S. (2015). Quantity and quality of language input in bilingual language learning development. In Nicoladis, E., & Montanari, S. (Eds.), *Lifespan Perspectives on Bilingualism*. Berlin: Mouton de Gruyter.
- Ushioda, E. (2001). *Language learning at university: Exploring the role of motivational thinking*. In Z. Dörnyei & R. Schmidt (Eds.), *Motivation and second language acquisition*. 91-124. Honolulu, HI: University of Hawaii Press.
- Vance, C. D. (2015). Decision-making considerations for mid-career army officers to pursue master's degrees. *Adult Learning*, 26(3), 109-115.
- Verma, M. H. (2005). Learner's attitude and its impact on language learning. Retrieved from <http://www.languageeduc.com>.
- Yan, J. (2007). Grammatical competents instrument Grammatical Competence of Fourth Year English Majors of Benguet State University. Benguet State University, La Trinidad, Benguet. Retrieved from: <http://asianscientificjournals.com/new/publication/>.
- Yigzaw, A. (2011). Students first language writing skills and their English language proficiency as predictors of their English language writing performance. *Journal of Languages and Culture*, 4(6), 109-114.
- Young, M. (2007). *Macao students' attitudes toward English: a post-1999 survey*. *World Englishes*, 25 (3/4), 479-490.
- Yu, Y. (2010). *Attitudes of learners toward English: A case of Chinese college students* (Doctoral dissertation). Ohio University. Retrieved from <http://www.ohiolink.edu>.
- Yu, B. (2010). Learning Chinese abroad: The role of language attitudes and motivation in the adaptation of international students in China. *Journal of Multilingual and Multicultural Development*, 31(3), 301-321.
- Zimmerman, B. J., & Bandura, A. (1994). Impact of self-regulatory influences on writing course attainment. *American educational research journal*, 31(4), 845-862.